

Emissions Testing Support Requirements: Rectangular Stack

Stack Port Locations

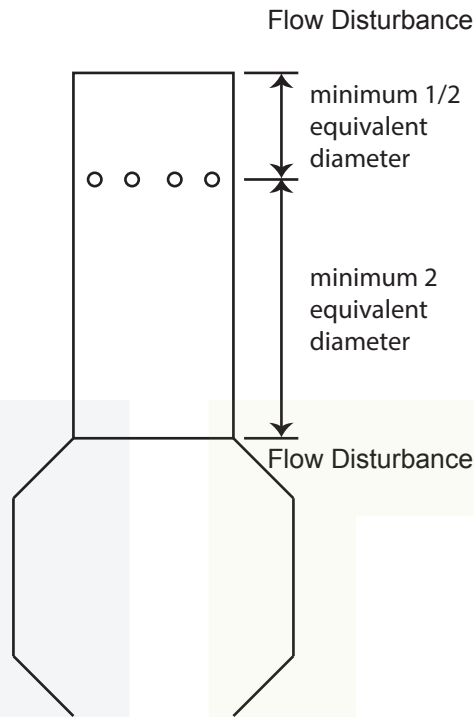

Stack Close-up

EXAMPLE:

Stack side with Ports (in.): 72"

- if 4 ports installed then..
- distribute the ports as shown

Change measurements as needed, based on width.

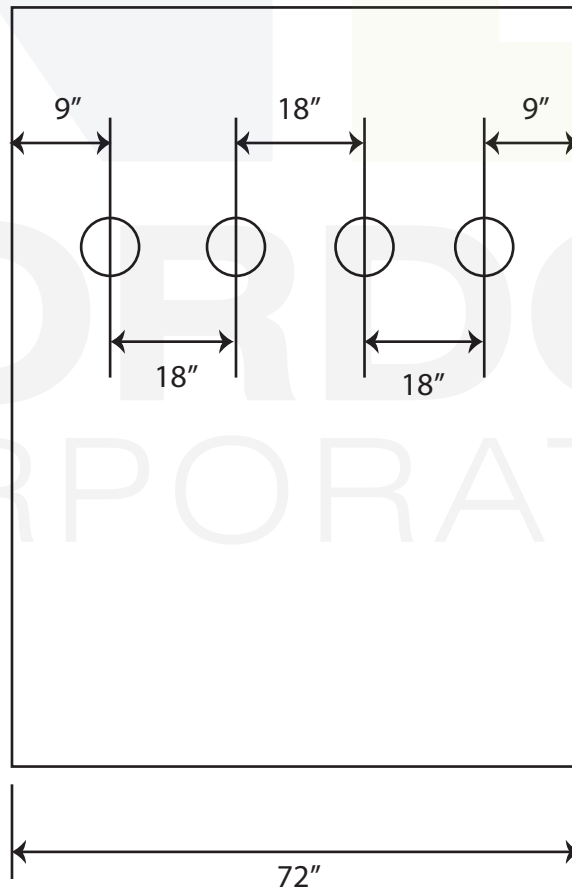

- Ports are located on one side only.
- number of ports is relative to stack width and flow disturbance locations but in general at a minimum of 4 ports are recommended.
- Port size is also based on stack size and test requirements. 4" 150 lb ports are recommended as a minimum and 6" 150lb ports as a maximum.